

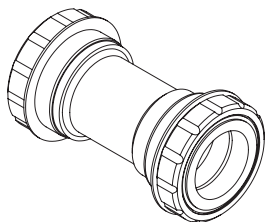

BB30 Road TO DUB TWIST-FIT BB System

TRiPEAK Product NO.
EMA-BB3029R-SR★TF12



Bearing Options

- ★ SB (Steel Bearing) / ★ CB (Ceramic Bearing)
- Bearing Size : 30 X 42 X 7mm (6806-2RS)

Replacement Bearing set
TRIPEAK item NO. SB : EMA-HP6806-2RS / CB : EMA-JC6806-2RS

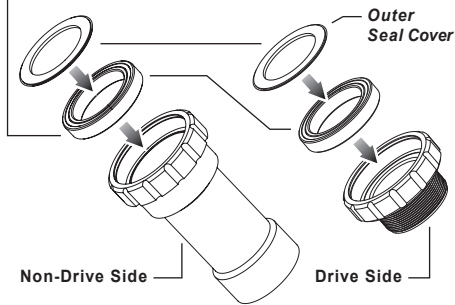

Step 1 PRESS IN

Non-DRIVE SIDE

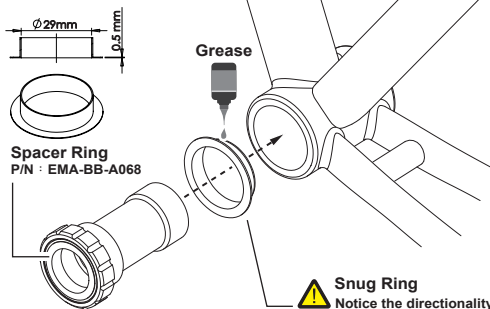

Step 2 TWIST-LOCK

DRIVE SIDE Cup set lock to 30Nm

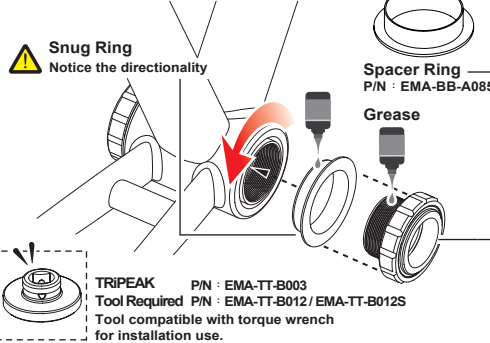

⚠ NOTICE

- To install TRIPEAK Bottom Bracket, we strongly recommend that you have a trained bicycle mechanic at your local bike shop.
- Do not alter this product in any way as it can cause unseen damage. Any modifications to this product will void the warranty.
- Make sure with the crankset are firmly attached to the bottom bracket. Improperly attached cranks can become detached from the BB set.
- When cleaning the bottom bracket set, only use mild soap and water. Never spray with high-pressure water. It will cause BB cup internal water ingress and influencing the bearing rolling lifetime.
- If you have any questions or concerns about this product Please feel free to contact us. E-mail: info@tripeakbearing.com

Snug-Ring PA+GF Mold & CNC Finished

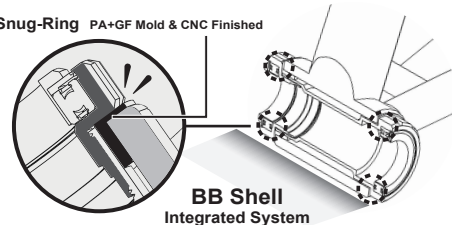

Installed-Width

